

N.º 448

Rosários 4[®]

Autumn/Winter Collection

Autumn/Winter Collection

NEON MIST

SIZE: 1

DESIGN:

Filipa Carneiro
@filipa_nionoi



BRUMA | 8, 25

60% MOHAIR KID | 40% MERINO WOOL

HERITAGE YARNS

BY ROSÁRIOS



n.º 448

Autumn/Winter Collection

P. 2

NEON MIST



BRUMA

60% MOHAIR KID | 40% MERINO WOOL

WORSTED/ARAN



100g
(3,52 oz)

120 METROS
METRES
131 YARDS

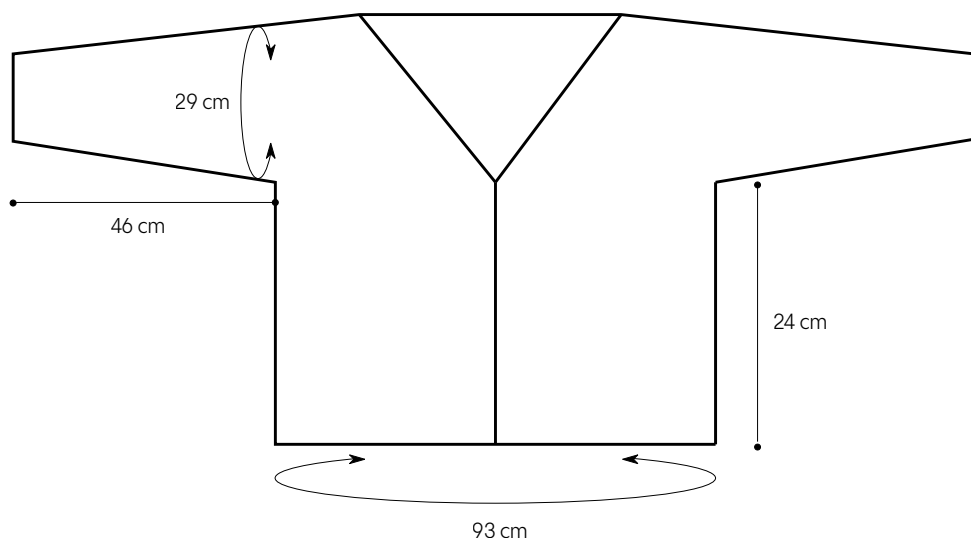

YARN

5 balls of **Bruma** from Heritage by Rosários in **color 08 – color A**;
1 ball of **Bruma** from Heritage by Rosários in **color 25 – color B**;

GAUGE

14 sts and 22 rows – 10 x 10 cm in stockinette stitch with 5 mm needles, washed and blocked. It is important to wash and dry the swatch as stitch count may change after the first wash.

NEEDLES

4.5 and 5 mm circular needles with 80 cm cable for the body and a 40 cm cable (or DPNs; or use the bigger cable and work in magic loop) for the sleeves. Adjust needle size if necessary to obtain the correct gauge.

NOTIONS

Stitch markers, tapestry needle, scrap yarn.

SIZES

1

FINISHED MEASUREMENTS

93 cm chest circumference (see final measurements in the schematic); these measurements include 15 cm of positive ease at the bust.

This cardigan is worked from the top down, seamless, with contiguous shoulders. Begin by casting on the back stitches and work increases along the shoulder lines and neckline. Once all shoulder increases are complete, begin shaping the sleeves with increases. At the armholes, place the sleeve stitches on hold and continue working the body. Next, return to the held sleeve stitches and work each sleeve from the armhole to the cuff. Finally, pick up stitches along the edges to knit the button band in double knitting.



With Color A and the larger needles, cast on 34 sts using a long-tail cast-on. Place markers as follows: p2, pm, p2, pm, p4, pm, p18, pm, p4, pm, p2, pm, p2.

Work the shoulder increases as follows:

Row 1 (RS): k1, **Kfb**, slm, k2, slm, **Kfb**, knit to 1 st before marker, **Kfb**, slm, knit to marker, slm, **Kfb**, knit to 1 st before marker, **Kfb**, slm, k2, slm, **Kfb**, k1. [inc 6 sts; 1 st on each front panel and 4 sts on back]

Row 2 (WS): purl to 1 st before marker, **Pfb**, slm, p2, slm, **Pfb**, purl to marker, slm, purl to marker, slm, purl to 1 st before marker, **Pfb**, slm, p2, slm, **Pfb**, purl to end. [inc 4 sts; 1 st on each front panel and 2 sts on back]

Row 3 (RS): knit to 1 st before marker, Kfb, slm, k2, slm, Kfb, knit to 1 st before marker, Kfb, slm, knit to marker, slm, Kfb, knit to 1 st before marker, Kfb, slm, k2, slm, Kfb, knit to end. [inc 6 sts; 1 st on each front panel and 4 sts on back]

Row 4 (WS): repeat Row 2. [inc 4 sts; 1 st on each front panel and 2 sts on back]

Row 5 (RS): knit to 1 st before marker, Kfb, slm, k2, slm, Kfb, knit to 1 st before marker, Kfb, slm, knit to marker, slm, Kfb, knit to 1 st before marker, Kfb, slm, k2, slm, Kfb, knit to end. [inc 6 sts; 2 sts on each front panel and 4 sts on back]

Row 6 (WS): purl to 1 st before marker, Pfb, slm, p2, slm, Pfb, (purl to marker, remove marker) x2, purl to 1 st before marker, Pfb, slm, p2, slm, Pfb, purl to end. [inc 4 sts; 1 st on each front panel and 2 sts on back]

You will have 8 sts on the front panels and 44 sts on the back. Remove the markers from the back panels, leaving only the markers on the shoulders.

Continue working the shoulder and neckline increases:

Row 1 (RS): k1, Kfb, knit to 1 st before marker, Kfb, slm, k2, slm, Kfb, knit to 1 st before marker, Kfb, slm, k2, slm, Kfb, knit to 2 sts before end, Kfb, k1. [inc 6 sts; 2 sts on each front panel and 2 sts on back]

Row 2 (WS): purl to 1 st before marker, Pfb, slm, p2, slm, Pfb, purl to 1 st before marker, Pfb, slm, p2, slm, Pfb, purl to end. [inc 4 sts; 1 st on each front panel and 2 sts on back]

Row 3 (RS): knit to 1 st before marker, Kfb, slm, k2, slm, Kfb, knit to 1 st before marker, Kfb, slm, k2, slm, Kfb, knit to end. [inc 4 sts; 1 st on each front panel and 2 sts on back]

Row 4 (WS): repeat Row 2. [inc 4 sts; 1 st on each front panel and 2 sts on back]

Repeat rows 1–4 once more. You will have: 18 sts on the front panels; 2 sts on each shoulder; 60 sts on the back

Move the markers and work the sleeve increases as follows:

Row 1 (RS): k1, Kfb, knit to 1 st before marker, pm, Kfb, remove marker, k2, remove marker, Kfb, pm, knit to 1 st before marker, slm, Kfb, remove marker, k2, remove marker, Kfb, slm, knit to 2 sts before end, Kfb, k1.

[17 sts in the fronts; 58 sts in the back; 6 sts in each sleeve]

Row 2 (WS): purl to end.

Row 3 (RS): knit to marker, slm, Kfb, knit to 1 st before marker, Kfb, slm, knit to marker, slm, Kfb, knit to 1 st before marker, Kfb, slm, knit to end. [inc 4 sts; 2 sts in each sleeve]

Row 4 (WS): purl to end.

Row 5 (RS): k1, Kfb, knit to marker, slm, Kfb, knit to 1 st before marker, Kfb, slm, knit to marker, slm, Kfb, knit to 1 st before marker, Kfb, slm, knit to 2 sts before end, Kfb, k1. [inc 6 sts; 2 sts in each sleeve; 1 st on each front panel]

Row 6 (WS): purl to end.

Row 7 (RS): knit to marker, slm, Kfb, knit to 1 st before marker, Kfb, slm, knit to marker, slm, Kfb, knit to 1 st before marker, Kfb, slm, knit to end. [inc 4 sts; 2 sts in each sleeve]

Row 8 (WS): purl to end.

Repeat Rows 5–8 once more.

Repetir as carrs 5 a 8 mais 1 vezes. Ficam 16 ms nas mangas e 20 ms nas frentes.

Continue working the sleeve increases as follows:

Row 1 (RS): k1, Kfb, k to marker, slm, Kfb, k to 1 st before marker, Kfb, slm, k to marker, slm, Kfb, k to 1 st before marker, Kfb, slm, k to last 2 sts, Kfb, k1. [increase 6 sts; 1 st at each front and 2 sts at each sleeve]

Row 2 (WS): purl to end.

Repeat rows 1 and 2 another 10 times. You will have: 38 sts sleeves and 31 sts in fronts.

SEPARATE THE SLEEVES: Knit to marker, remove marker, place the next 38 sts on scrap yarn and leave them on hold for the sleeve, backwards loop cast on 4 sts, remove marker, knit to next marker, remove marker, place the next 38 sts on a scrap yarn and leave them on hold for the sleeve, backwards loop cast on 4 sts, remove marker, knit to end. You will have 130 sts for the body.

BODY

Work the body in stockinette stitch until it measures approx. 19 cm from the underarm (or 5 cm less than the desired length). Change to the smaller needle and work the hem in 1x1 rib as follows:

Row 1 (RS): k2, p1, k2tog, (p1, k1) rep to last st, k1. [129 sts]

Row 2 (WS): p2, (k1, p1) rep to last st, p1.

Row 3: k2, (p1, k1) rep to last st, k1.

Repeat rows 2 and 3 another three times. Repeat row 2 once more. Bind off all sts in rib pattern.

SLEEVES

With RS facing and starting at the center of the underarm cast-on stitches, pick up and knit 2 sts along one side of the underarm cast-on; place on the left needle the 38 sts held for the sleeve and knit them; then pick up and knit 2 sts along the remaining side of the underarm cast-on. You will have 42 sts for the sleeve. Join to work in the round, place a BOR (beginning of round) marker, and knit all rounds until the sleeve measures approx. 41 cm from the underarm (or 4 cm less than the desired total length).

Work decreases as follows: (k2tog) rep to 2 sts from end, k2. [22 sts]

Work the cuff in 1x1 rib as follows: (k1, p1) rep to end. Repeat this round 7 more times. Bind off all sts in rib pattern.

BUTTONBAND

With RS facing, using color B and the smaller needle, start at the lower edge of the right front hem and pick up and knit 1 st in each row along the edge up to the shoulder; then pick up and knit (34, 36, 36 · 38, 38, 38 · 40, 40, 40) sts along the cast-on edge; finally, pick up and knit 1 st in each row along the left front edge down to the hem. Cut the yarn and leave all sts on hold on the needle.

Place markers to indicate the position of the buttonholes along the right front edge, between the hem and the beginning of the neckline. Distribute the buttons evenly along the edge — I chose to place 3 buttons, but you can adjust this to your preference. At each button position, place two markers separated by 3 sts (since each buttonhole will be worked over 6 rows). Check the stitch count between the sets of markers and adjust if necessary so that the spacing between buttonholes is even. Leave the first marker of each pair in place — it will indicate where to work each buttonhole later on. See the diagram below:

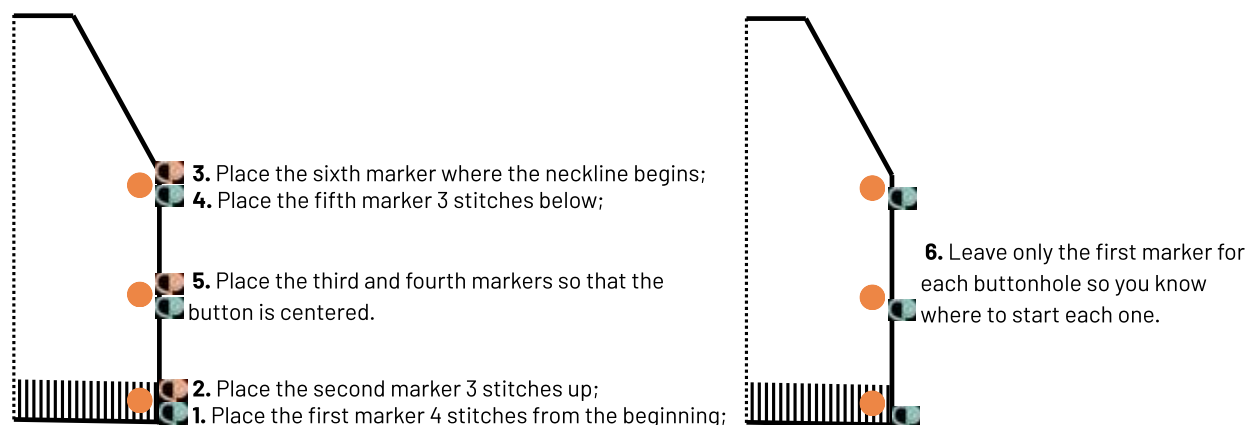

Using the same needle and color B, cast on 15 sts with a tubular Italian cast-on (see tutorial video).

Turn work and begin knitting in double knitting as follows:

Row 1 (RS): (k1, sl1 wyif) x 7, k1, turn.

Row 2 (WS): (sl1 wyif, k1) x 7, sl1 wyif.

Row 3: (k1, sl1 wyif) x 7, **k2tog tbl** (joining the last cast-on st with the first picked-up st along the front edge), turn.

Row 4: (sl1 wyif, k1) x 7, sl1 wyif.

Repeat Rows 3 and 4 until you reach the marker for the first buttonhole.

Work the buttonhole as follows:

Row 1 (RS): (k1, sl1 wyif) x 3, k1, turn work (7 sts worked; remaining sts stay on the needle).

Row 2 (WS): (sl1 wyif, k1) x 3, sl1 wyif.

Repeat rows 1 and 2 once more.

Row 5 (RS): (k1, sl1 wyif) x 3, k1, cut yarn; join a new strand and work the remaining sts of the button band as follows: (sl1 wyif, k1) x 3, sl1 wyif, **k2tog tbl** (remove the marker before making the decrease), turn.

Row 6 (WS): (sl1 wyif, k1) x 4.

Row 7 (RS): (sl1 wyif, k1) x 3, sl1 wyif, **k2tog tbl**, turn.

Row 8 (WS): (sl1 wyif, k1) x 4.

Row 9 (RS): (sl1 wyif, k1) x 3, sl1 wyif, **k2tog tbl**, turn.

Row 10 (WS): (sl1 wyif, k1) x 7, sl1 wyif (15 sts again).

Row 11: (k1, sl1 wyif) x 7, **k2tog tbl**, turn.

Row 12: (sl1 wyif, k1) x 7, sl1 wyif.

Repeat Rows 11 and 12 until reaching the second buttonhole marker.

Work the buttonhole again by repeating Rows 1–10.

Repeat Rows 11 and 12 until reaching the third buttonhole marker.

Work the buttonhole again by repeating Rows 1–10.

Repeat Rows 11 and 12 until all picked-up sts along the front edge have been worked.

Cut yarn and, using a tapestry needle, bind off the button band with a tubular bind-off (see tutorial video).

FINISHING

Sew the buttons. Weave in all yarn ends using a tapestry needle. Gently wash the piece with a mild detergent. Block the piece, adjusting it to the final measurements.

ABBREVIATIONS

k	knit
p	purl
cm	cm: centimeters
approx	approximately
st/sts	stitch/stitches
rnd/ rnds	round/ rounds
rep	repeat
RS	right side
WS	wrong side
pm	place marker
slm	slip marker
BOR	beginning of round marker
inc	increases
sl1wyif	slip 1 st purlwise and with the yarn in front of the work
k2tog	knit 2 stitches together
K3tog	knit 3 stitches together
Kfb	knit front and back (knit 1 stitch but don't drop it off left-hand needle; knit the same stitch again through back loop and drop it off the needle)
Pfb	purl front and back (purl 1 stitch but don't drop it off left-hand needle; purl the same stitch again through back loop and drop it off the needle)
k2tog tbl	knit 2 stitches together through back loop
Stockinette stitch	Stockinette stitch: knit all right side rows and purl all wrong side rows (in the round: knit all rounds)



SUPPORT VIDEOS

Montagem tubular italiana

Remate tubular

SUPPORT

If you need help with this pattern, please contact:

filipa.nionoi@gmail.com

Share your photos on social media using:

#NEONMIST #FILIPACARNEIRODESIGNS #ROSARIOS4NEONMIST #ROSARIOS4
#ROSARIOS4BRUMA

YARN

Where can I find this yarn? Send an email to:

geral@rosarios4.com

KNIT FOR A HAPPIER WORLD · KNIT FOR A HAPPIER WORLD ·
Rosários4 · KNIT FOR A HAPPIER WORLD · KNIT FOR A HAPPIER WORLD

Rua das Grutas, 13
Apartado 123
2485-059 Mira de Aire
PORTUGAL
Tel. +351 244 448 300
info@rosarios4.com

www.rosarios4.com



Rosários 4®

CENTRO 2030
Os Fundos Europeus mais próximos de si.

