

N.º 400

Rosários 4[®]

Spring/Summer Collection

Spring/Summer Collection

HIBISCO

SIZE: 1

DESIGN:

Filipa Carneiro
@filipa_nionoi



ALFAMA · 43



100% LINEN



n.º 400

Spring/Summer Collection

P. 2

HIBISCO



ALFAMA



100% LINEN

LIGEIRO/LIGHT
LIGERO

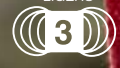

50g
1.75 oz

125

METROS
METRES

137

YARDS

Rosários 4

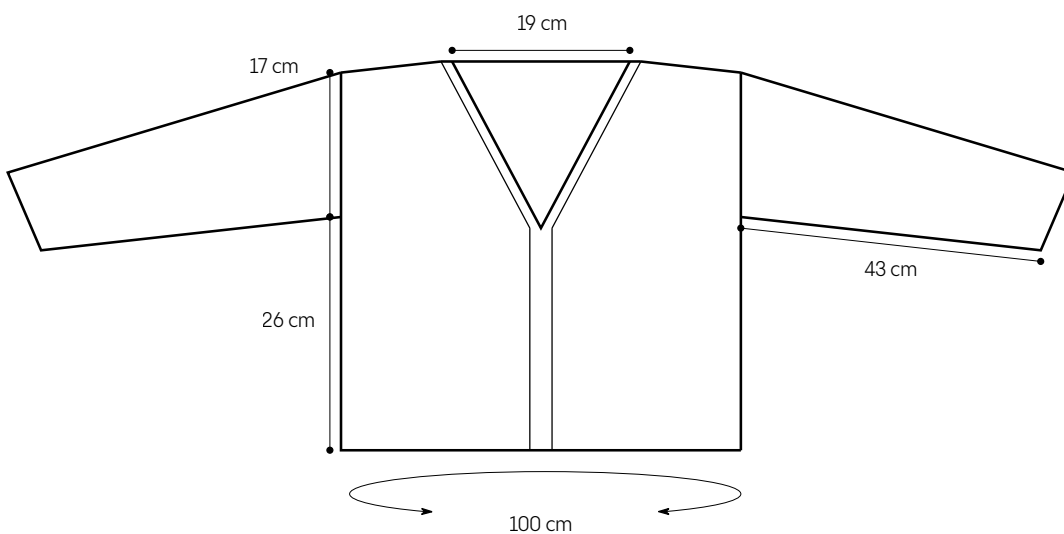

YARN

7 skeins of **ALFAMA** from **Rosários4, color 43**.

GAUGE

24 sts and 30 rows – 10 x 10 cm in stockinette stitch with 3.5 mm needles, knitted in the round, washed and blocked (it's important to wash and block your swatch in order to get the correct gauge).

NEEDLES

2.5 and 3 mm circular needles (if necessary, adjust the needle size to match the gauge).

NOTIONS

Tapestry needle, stitch markers, locking stitch markers, waste yarn.

SIZE

1.

FINISHED MEASUREMENTS

100 cm final bust measurements (refer to the schematic for more measurements); measures with approx. 22 cm of positive ease included.

This sweater is knitted from the top down and seamlessly. We begin by working the back down to the armhole and leave it on hold. Then we work each front from stitches picked up at the shoulder and shape the neckline with increases. In the armhole, we join all the pieces and work the body in the round. The sleeves are knitted from the top down, beginning with the stitches picked up around the armhole.



BACK

With waste yarn and the bigger needles, long tail cast on 3 sts. Join the Alfama yarn and knit the 3 sts. Turn the work and work in i-cord as follows: (k3, place the 3 sts back to the left-hand needle) rep until you complete 48 rows. Slip the 3 sts on the right-hand needle onto a locking stitch marker and leave on hold. Cut the thread.

Backwards loop cast on 36 sts, pick up and knit 46 sts along the i-cord (pick up 1 st for every row), backwards loop cast on 36 sts. There are 118 sts on the needle. Shape shoulders with short rows:

Row 1 (WS): p to end.

Row 2 (RS): k90, turn.

Row 3: DS, p62, turn.

Row 4: DS, k to 4 sts after the DS, turn.

Row 5: DS, p to 4 sts after the DS, turn.

Repeat rows 4 and 5, 5 more times.

Row 16: DS, k to end.

Row 17: p to end.

Work 48 rows in stockinette stitch. The armhole measures approx. 17 cm from the shoulder. Leave all sts on hold while working the fronts.

LEFT FRONT

Place on the larger needles the 3 stitches on hold from the back i-cord and knit; from the RS, pick up and knit 36 sts over the sts on the back cast-on (on the left shoulder side). There are 39 sts on the needle. Shape shoulder with short rows:

Row 1 (WS): p to 7 sts from end, pm, k1, p2, k1, sl3 wyif.

Row 2 (RS): k3, p1, k2tog, yo, p1, slm, k1, turn.

Row 3: DS, p to marker, slm, k1, p2, k1, sl3 wyif.

Row 4: k3, p1, yo, ssk, p1, slm, k to 4 sts after the DS, turn.

Row 5: DS, p to marker, slm, k1, p2, k1, sl3 wyif.

Row 6: k3, p1, k2tog, yo, p1, slm, k to 4 sts after the DS, turn.

Row 7: DS, p to marker, slm, k1, p2, k1, sl3 wyif.

Repeat rows 4 to 7, 2 more times.

Row 16: k3, p1, yo, ssk, p1, slm, k to end.

Row 17: p to marker, slm, k1, p2, k1, sl3 wyif.

Work the neckline increases every 2 rows:

Row 1 (RS): k3, p1, k2tog, yo, p1, slm, **m1r**, k to end.

Row 2 (WS): p to marker, slm, k1, p2, k1, sl3 wyif.

Row 3: k3, p1, yo, ssk, p1, slm, **m1r**, k to end.

Row 4: p to marker, slm, k1, p2, k1, sl3 wyif.

Repeat rows 1 to 4, 11 more times. [63 sts]

RIGHT FRONT

From the RS and with bigger needles, pick up and knit 36 sts over the cast-on sts on the back (on the right shoulder side), undo the provisional cast-on and place the 3 sts of the back i-cord on the needles and knit. There are 39 sts on the needle. Shape shoulder with short rows:

Row 1 (WS): sl3 wyif, k1, p2, k1, pm, p to end.

Row 2 (RS): k to marker, slm, p1, yo, ssk, p1, k3.

Row 3: sl3 wyif, k1, p2, k1, slm, p1, turn.

Row 4: DS, k to marker, slm, p1, k2tog, yo, p1, k3.

Row 5: sl3 wyif, k1, p2, k1, slm, p to 4 sts after the DS, turn.

Row 6: DS, k to marker, slm, p1, yo, ssk, p1, k3.

Row 7: sl3 wyif, k1, p2, k1, slm, p to 4 sts after the DS, turn.

Repeat rows 4 to 7, 2 more times.

Row 16: DS, k to marker, slm, p1, k2tog, yo, p1, k3.

Row 18: sl3 wyif, k1, p2, k1, slm, p to end.

Work the neckline increases every 2 rows:

Row 1 (RS): k to marker, **A1E**, slm, p1, yo, ssk, p1, k3.

Row 2 (WS): sl3 wyif, k1, p2, k1, slm, p to end.

Row 3: k to marker, **A1E**, slm, p1, k2tog, yo, p1, k3.

Row 4: sl3 wyif, k1, p2, k1, slm, p to end.

Repeat rows 1 to 4, 11 more times. [63 sts]

JOIN FRONTS AND BACKS TO WORK IN THE ROUND:

1. Work the right front as follows: k to marker, slm, p1, yo, ssk, p1, stop leaving the 3 sts of the i-cord selvage on the left-hand needle, without working;
2. With the LD facing you, remove the 3 sts from the left front i-cord selvage onto an auxiliary needle;
3. Place the auxiliary needle parallel to the left-hand needle where the sts of the right front selvage are located;
4. Knit each stitch of the right-front i-cord selvage together with the corresponding stitch of the left-front i-cord selvage, i.e.: 3 x k2tog;
5. Place the remaining stitches from the left front on the left-hand needle and work as follows: p1, k2tog, yo, p1, slm, k to end; [123 sts in front]
6. Place a marker, backwards loop cast on 1 st;
7. Place the 118 sts on hold from the back on the left-hand needle and knit;
8. Place a marker, backwards loop cast on 1 st. Join to work in the round and place the BOR.

Work the neckline decreases as follows:

Rnd 1: k to marker, slm, p1, k2, p1, k3,1L, k2, p1, slm, (k to marker, slm, sl1 wyif) x 2.

Rnd 2: k to marker, slm, p1, k2tog, yo, p1, **cdd**, p1, yo, ssk p1, slm, (k to marker, slm, p1) x 2. [121 sts in front]

Rnd 3: k to marker, slm, p1, k2, p1, 1M, p1, k2, p1, slm, (k to marker, slm, sl1 wyif) x 2.

Rnd 4: k to marker, slm, p1, yo, ssk, **p3tog**, k2tog, yo, p1, slm, (k to marker, slm, p1) x 2. [119 sts in front]

Rnd 5: k to marker, slm, p1, k2, p1, k2, p1, slm, (k to marker, slm, sl1 wyif) x 2.

BODY

Work the body in stockinette stitch with faux seams on the sides:

Rnd 1: k to marker, slm, p1, yo, ssk, p1, k2tog, yo, p1, slm, (k to marker, slm, p1) x 2.

Rnd 2: k to marker, slm, p1, k2, p1, k2, p1, slm, (k to marker, slm, sl1 wyif) x 2.

Rnd 3: k to marker, slm, p1, k2tog, yo, p1, yo, ssk, p1, slm, (k to marker, slm, p1) x 2.

Rnd 4: k to marker, slm, p1, k2, p1, k2, p1, slm, (k to marker, slm, sl1 wyif) x 2.

Continue working in the established pattern, repeating Rnds 1 to 4, until the body measures 24 cm from the armhole (or 1 cm less than the desired length).

Change to smaller needle and work in garter stitch:

Rnd 1: p to end (remove all markers).

Rnd 2: k to end.

Repeat rnds 1 and 2, 1 more time. Work rnd 1 more time. Bind off all sts knitwise.

SLEEVES

From LD, with bigger needles and beginning in the armhole: pick up and knit 1 st over the cast-on st in the armhole, pick up and knit 35 sts along the selvage from the armhole up to the shoulder (pick up approx. 3 sts every 4 rows); pick up and knit 35 sts along the selvage from the shoulder down to the armhole. There are 71 sts left on the needles. Join to work in the round and place the BOR. Knit 8 rnds.

Work the decreases for the cuff:

Decrease rnd: k1, **ssk**, k to 3 sts before the BOR, **k2tog**, k1. [dec 2 sts]

Knit 11 rnds.

Repeat the decrease rnd every 12 rnds, 5 more times. [59 sts]

Continue knitting until the sleeve measures approx. 42 cm from the armhole (or 1 cm less than the desired length).

Change to smaller needle and work in garter stitch:

Rnd 1: p to end.

Rnd 2: k to end.

Repeat rnds 1 and 2, 1 more time. Work rnd 1 more time. Bind off all sts knitwise. Repeat for the other sleeve.

FINISHING

Weave in all ends with a tapestry needle. Wash carefully with mild soap. Block garment to final measurements.

ABBREVIATIONS

- k** knit
p purl
cm centimeters
Rep repeat
approx. approximately
RS right side
WS wrong side
st/sts stitch/stitches
rnd/rnds round/rounds
pm place marker
slm slip marker
BOR beginning of round marker
sl1wyif slip 1 st purlwise and with the yarn in front of the work.
sl3wyif slip 3 sts purlwise and with the yarn in front of the work.
k2tog knit 2 stitches together.
p3tog purl 3 stitches together.
ssk slip, slip, knit (slip a stitch as if to knit, slip a second stitch as if to knit, insert left needle into the front of the slipped stitches and knit).
cdd centered double decrease (slip 2 stitches together as if to knit, knit 1 stitch, with left hand needle pass slipped stitch over).
yo yarn over
m1l make one left (insert the left-hand needle, from front to back, under the strand of yarn which runs between the stitch just worked and the next stitch on the left-hand needle. Knit this st through the back loop).
m1r make one right (insert the left-hand needle, from back to front, under the strand of yarn which runs between the stitch just worked and the next stitch on the left-hand needle. Knit this st through the front loop).
Stockinette stitch knit all right side rows and purl all wrong side rows (in the round: knit all rounds).
German short-rows:
DS double stitch
On right side rows knit to turning point; turn and slip the first stitch purl-wise with yarn in front, bring yarn over the needle to the back of work and pull tight - this creates the double stitch (DS). Bring yarn between needles to front of work to begin purling.
On wrong side rows purl to turning point; turn and bring yarn to front between needles, slip the first stitch purl wise; bring yarn over the needle to the back of work and pull tight - this creates the double stitch (DS); begin knitting.
On following rows/rounds work DS's as single stitches, knitting or purling both legs of the DS together.

I would love to see the progress of your work and the final garment, please share your photos on social media using:

#HIBISCO #FILIPACARNEIRO #ROSARIOS4ALFAMA #ROSARIOS4

YARN

Where can I find this yarn? Send an email to:

geral@rosarios4.com

Rua das Grutas, 13
Apartado 123
2485-059 Mira de Aire
PORTUGAL
Tel. +351 244 447 300
info@rosarios4.com

www.rosarios4.com



Rosários 4®